



**KEMENTERIAN PELAJARAN MALAYSIA**

**NKRA - PENDIDIKAN**

**INSTRUMEN SARINGAN**

**LITERASI MENULIS**

**SARINGAN 1**

**TAHUN 3**

**2013**

**MAKLUMAT MURID:**

NAMA : .....

KELAS : .....

JANTINA:           LELAKI (    )           PEREMPUAN (    )

1a. Tulis huruf **vokal** yang disebut oleh guru.

1.	2.	3.	4.	5.
----	----	----	----	----

1b. Tulis huruf **konsonan** yang disebut oleh guru.

1.	2.	3.	
4.	5.	6.	7.
8.	9.	10.	

**Nota guru:**

- Konstruk 1: Keupayaan menulis huruf vokal dan huruf konsonan.
- Huruf besar atau huruf kecil boleh diterima.

2. Lengkapi perkataan berdasarkan gambar.

Contoh:

k a s



r u s a

i r a

1.



s a

a e k

2.

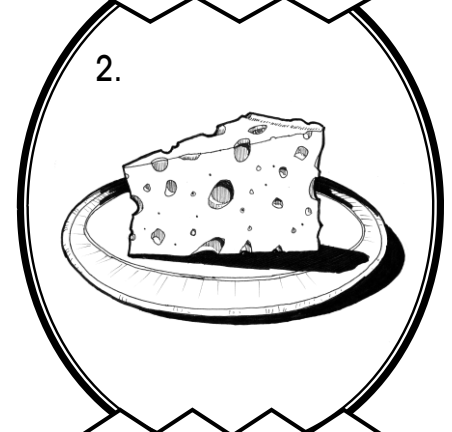

j u

c o i

3.

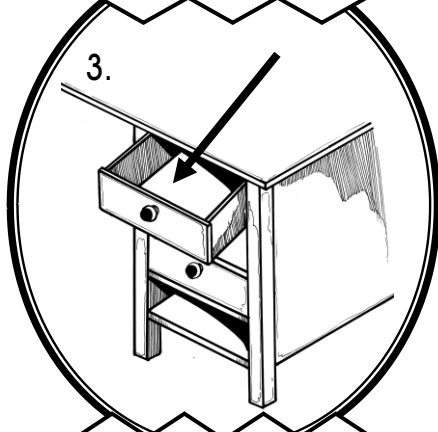

l a

e u d

4.

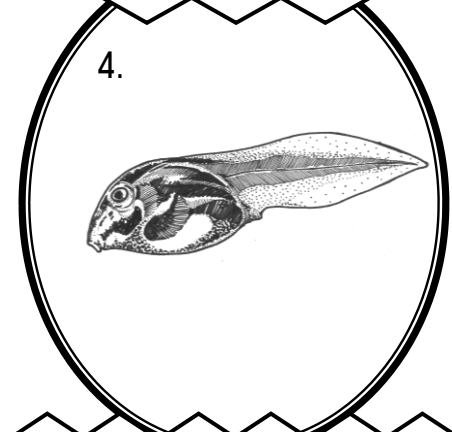

b e r u

o t a

5.

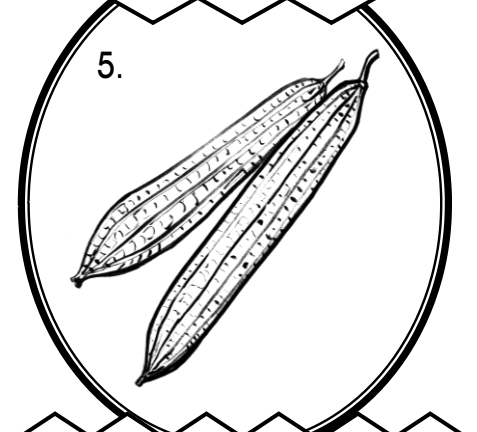

p e l a

Nota guru:

- Konstruk 2: Keupayaan menulis suku kata terbuka.
- Guru perlu menyebut perkataan berdasarkan gambar.

### 3. Tulis perkataan berdasarkan gambar.

Contoh:

la la li

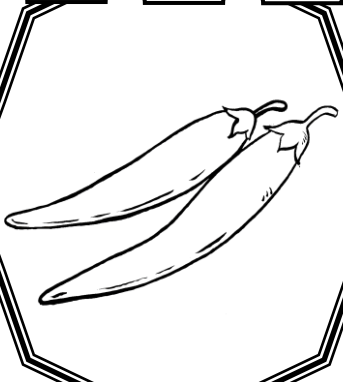

ci li

**cili**

---

ka ku ke

1.



pa li

---

ti ta to

2.

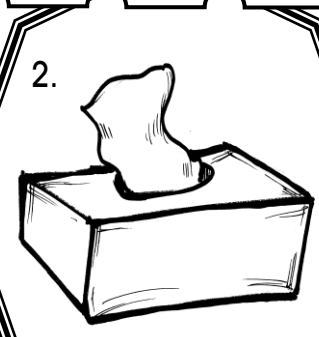

su

---

fi fe fo

3.



to

---

bo ba bu

4.

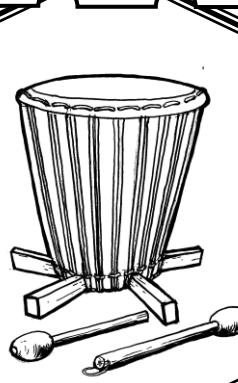

re na

---

pu pi pe

5.

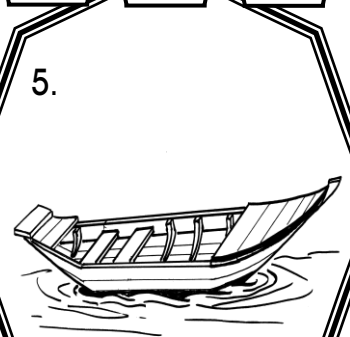

ra hu

---

#### Nota guru

- Konstruk 3: Keupayaan menulis perkataan yang mengandungi suku kata terbuka.
- Guru perlu menyebut perkataan berdasarkan gambar.

4. Lengkapi perkataan berdasarkan gambar.

Contoh:

~~l~~ ~~i~~ ~~a~~ ~~s~~

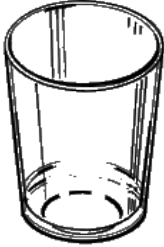

g e l a s

a m t u

1.



s e

a g r u

2.



p u

k t i e

3.



r a

s p a o

4.



m e n

n a m i

5.



c e r

Nota guru:

- Konstruk 4: Keupayaan menulis suku kata tertutup.
- Guru perlu menyebut perkataan berdasarkan gambar.

5. Tulis perkataan berdasarkan gambar.

Contoh:

 yum yam yim  
a yam → ayam

1.  but bit bat  
u → \_\_\_\_\_

2.  kel kul kal  
tu → \_\_\_\_\_

3.  her hur hor  
le → \_\_\_\_\_

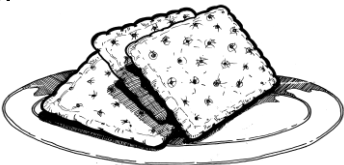
4.  bus bis bas  
kut → \_\_\_\_\_

5.  pin pen pon  
dok → \_\_\_\_\_

Nota guru:

- Konstruk 5: Keupayaan menulis perkataan yang mengandungi suku kata tertutup.
- Guru perlu menyebut perkataan berdasarkan gambar.

6. Tulis perkataan berdasarkan gambar.

Contoh:

cong cing cung



da cing

**dacing**

1. sing sung song

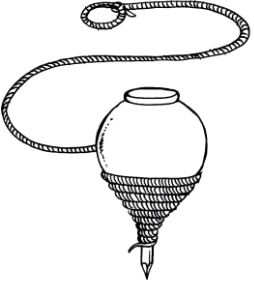

ga

**gasing**

2. reng rang rung

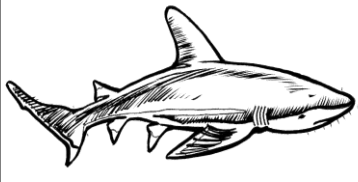

je

**ikan**

3. cong ceng cing

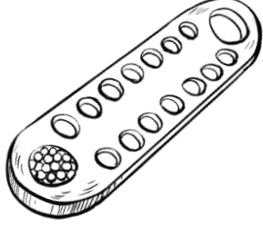

kak

**kekong**

4. lung lang long

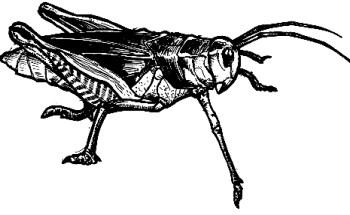

be la

**belalang**

5. teng tang tung



ko lok

**kekong**

Nota guru:

- Konstruk 6: Keupayaan menulis perkataan yang mengandungi suku kata tertutup 'ng'.
- Guru perlu menyebut perkataan berdasarkan gambar.

7. Tulis perkataan berdasarkan gambar.

Contoh:

~~wai~~ cai kai

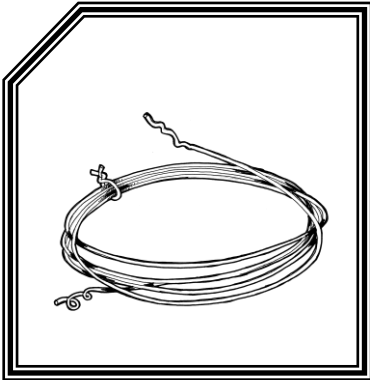

da wai

dawai

sau tau bau

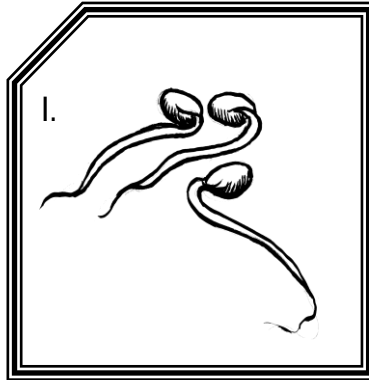

ge

lai cai tai

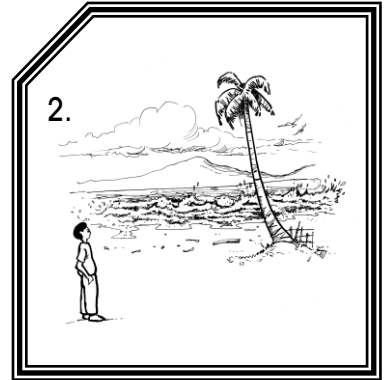

pan

soi doi loi

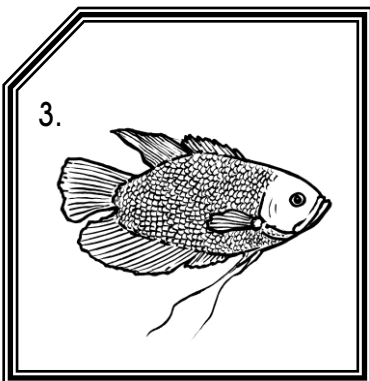

ka

ikan

bai gai kai

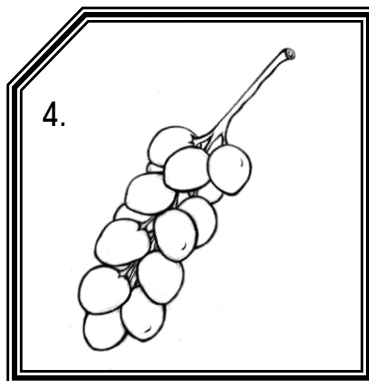

ram

jau mau tau

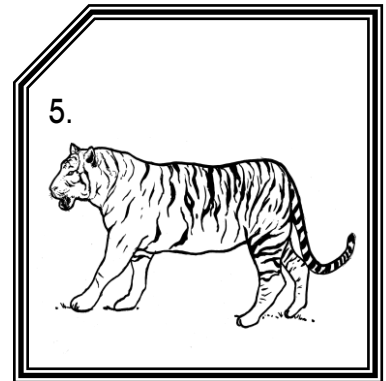

ha ri

Nota guru:

- Konstruk 7: Keupayaan menulis perkataan yang mengandungi diftong.
- Guru perlu menyebut perkataan berdasarkan gambar.



8. Susun huruf bagi membentuk perkataan berdasarkan gambar.

Contoh:

i u a



p o p i a

**popia**

e i u

1.

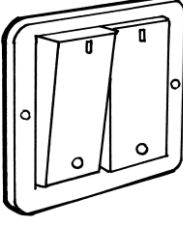

s s

u a o

2.



l k

i a u

3.

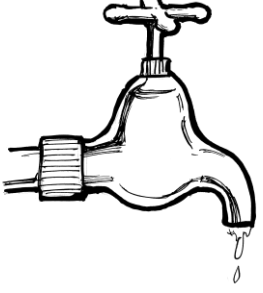

p p

u e a

4.



s h

u a i

5.



p n o

**Nota guru:**

- Konstruk 8: Keupayaan menulis perkataan yang mengandungi vokal berganding.
- Guru perlu menyebut perkataan berdasarkan gambar.

9. Tulis perkataan berdasarkan gambar.

Contoh:

~~nyet~~ nyat nyot



mo nyet

monyet

syun syan syen

1.

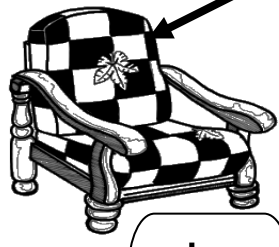

ku

\_\_\_\_\_

ngi ngu nga

2.



te li

\_\_\_\_\_

tre tro tra

3.



li

\_\_\_\_\_

sta sto sti

4.

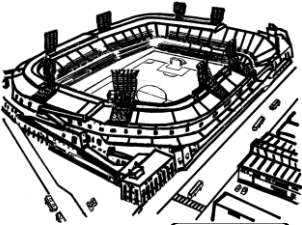

di um

\_\_\_\_\_

ske ska sku

5.

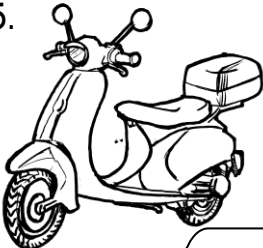

ter

\_\_\_\_\_

Nota guru:

- Konstruk 9: Keupayaan menulis perkataan yang mengandungi digraf dan konsonan bergabung.
- Guru perlu menyebut perkataan berdasarkan gambar.

10. Tuliskan perkataan berdasarkan gambar.

Contoh:

terjerat

~~terputus~~

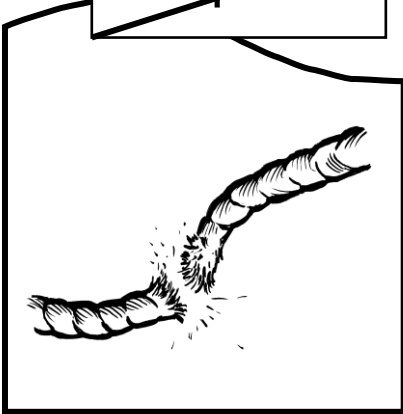

terputus

lompatan

tarian



melontar

mendaki

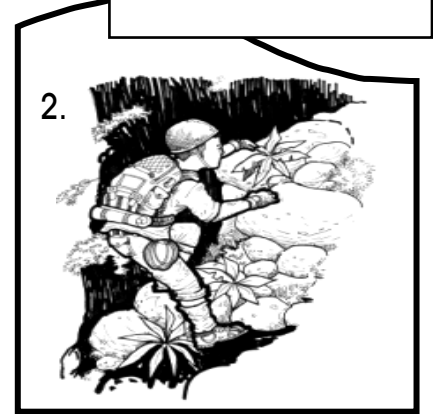

berjalan

bersorak



melukis

menyanyi



bertongkat

berbual



Nota guru:

- Konstruk 10: Keupayaan menulis perkataan berimbuhan awalan dan akhiran.
- Guru perlu menyebut perkataan berdasarkan gambar.

11. Susun perkataan supaya menjadi ayat yang betul.

Contoh:

adik kucing comel

kucing adik comel

---

1. halia sedang ibu hiris

---

2. berkhemah di tepi kami pantai

---

3. udang membeli di pasar dan ketam emak

---

Nota guru:

Konstruk 11: Keupayaan menulis ayat mudah.

12. Tulis ayat berdasarkan gambar.

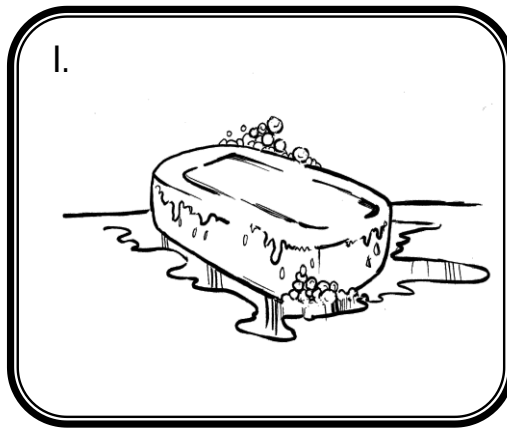

---

---

---

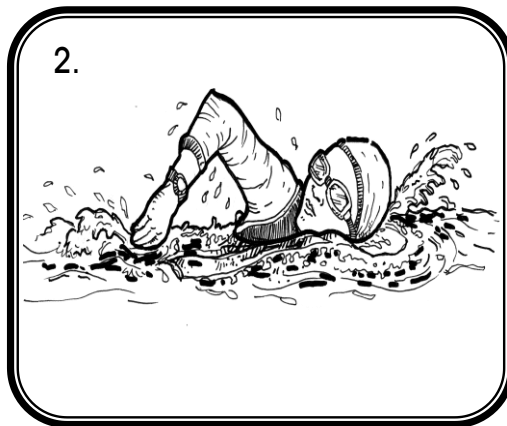

---

---

---

**Nota guru:**

- Konstruk 12: Keupayaan menulis ayat berdasarkan bahan rangsangan.
- Guru perlu menyebutkan gambar.